

Roof Flashings



RoofScreen offers several types of specially fitted roof flashing boots for proper waterproofing of our Roof Attachment Systems. This guide outlines the different types and provides a selection guide to help choose the correct flashing.

Square Flashings:

Our most common Roof Attachment System, shown in Figure 1, uses 6" square Base Supports. The flashings for this system are also square and slightly tapered from top to bottom to allow an easy slip fit during installation.

To accommodate roof insulation, the Base Supports are available in heights from 8" to 18". The distance they extend above the roof insulation determines the required flashing height (see Figure 2). Since the industry standard for flashing height is 8", RoofScreen square flashings are offered in 9" tall for metal flashings and 10" tall for single ply flashings. The flashings can be field trimmed to the desired height. The flashing should terminate as closely as possible to the top of the Base Support without extending above the top. They should also not be installed more than 1/2" below the top.

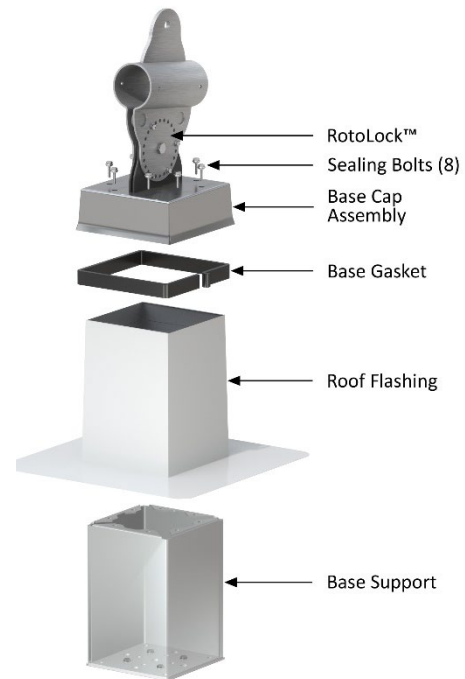

Figure 1

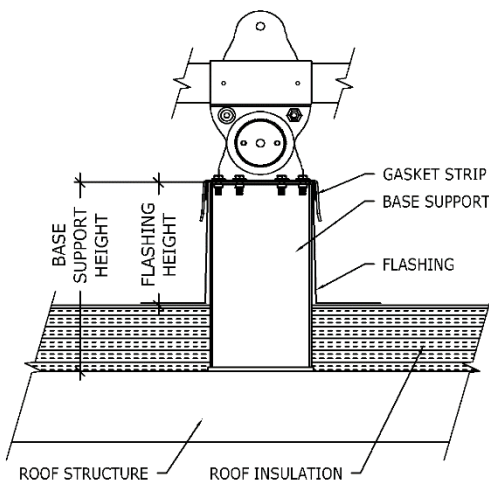

Figure 2

After the flashing is installed, an EPDM rubber gasket strip is applied around the top edge of the flashing. When the Base Assembly is installed, the Base Cap compresses the gasket, creating a seal. For more information about the Roof Attachment System, please see our Design Guide at www.roofscreen.com/technical-info/product-literature.php.

RoofScreen Flashings
Updated 01.03.2022

www.roofscreen.com



Round Flashings:

For our Round Post Roof Attachment Systems, we offer 12” tall round flashings in TPO, PVC and 4lb Lead. With this Round Post system, the flashings are installed using industry standard caulk and band method of sealing the flashing to the post. Caulking is applied between the flashing and the steel tube, then clamped with the worm drive draw band. Caulking is applied around the top of the flashing for added protection. To protect the caulking from weather, a tight fitting EPDM rubber storm collar is fitted over the steel tube above the clamped connection.

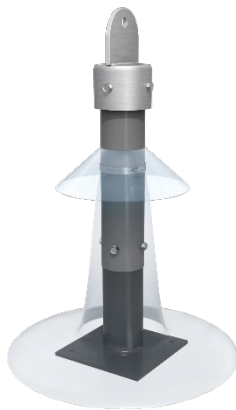

Figure 3

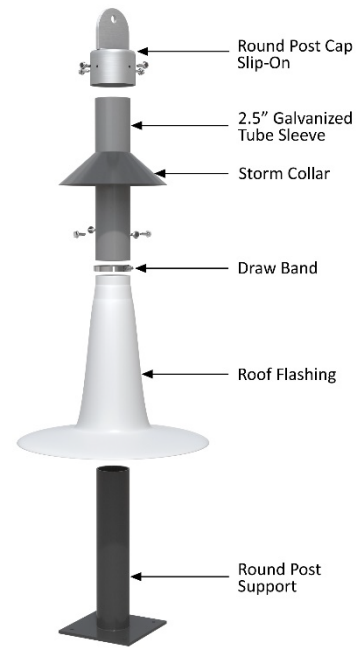

Figure 4

FLASHING SELECTION GUIDE		
Roofing Type	Round Flashing	Square Flashing
Built Up	12” Lead Flashing 2.75” Round, P/N F19	9” All Galvanized, P/N F24 9” Galvanized with Lead Base, P/N F26
TPO Single Ply	12” TPO Flashing 2.75” Round, P/N F20	10” TPO Flashing White, P/N F14
PVC Single Ply	12” PVC Flashing 2.75” Round, P/N F21	10” PVC Flashing White, P/N F18
EPDM	Field wrap by roofing contractor, or use any of our metal flashings (see notes below)	
Sprayed Foam	Field wrap by roofing contractor, or use any of our metal flashings (see notes below)	
Metal Roofing	Field fabricate or use standard Dektite rubber flashings (see notes below)	

Notes

RoofScreen Flashings
Updated 01.03.2022

www.roofscreen.com



Special Materials Available:

Metal flashings can be ordered in copper or stainless steel if required. Please contact us for pricing and lead time.

All Galvanized:

Riser and base flange are 24ga galvanized steel. These flashings are useful when the flange can be nailed down to the roof (i.e. wood structure), or when the roofing system will be adhered to the flange.

Galvanized with Lead Base:

Riser is 24ga galvanized steel and base flange is 4lb lead. Use this flashing when the flange cannot be nailed down (i.e. over rooftop insulation or on concrete deck). The lead flange sits on top of the insulation and can be roofed in to the roofing system without nailing.

TPO Single Ply:

We offer TPO flashings in 60mil white generic TPO material. The standard height is 10" for square and 12" for round. If a specific manufacturer's material is required for warranty purposes, please contact the manufacturer directly.

PVC Single Ply:

We offer PVC flashings in 60mil white generic PVC material. The standard height is 10" for square and 12" for round. If a specific manufacturer's material is required for warranty purposes, please contact the manufacturer directly.

EPDM Single Ply:

We do not offer a prefabricated flashing for EPDM. Our recommendation is to have the roofing contractor field wrap the Base Supports using standard methods recommended by the roofing material manufacturer. Alternatively, some roofers prefer to adhere the EPDM roof membrane to the flange of our stainless or lead flashings using peel-and-stick tape.

Sprayed Foam:

Foam roofing can be sprayed against the Base Supports without the use of flashings. Reinforcing membrane and the final coating of the roofing system should be wrapped up to the top of the Base Support. Alternatively, one of our metal flashings could be used for added waterproofing security.

Metal Roofing:

There are many types of metal roofing systems, and many ways of flashing around penetrations depending on the manufacturer of the metal roofing and the type of system used. Typically, the metal roofing is cut out around the Base Support location allowing the Base Support to attach to the structural member below. The method of flashing could be a custom field fabricated saddle integrated into the metal roofing seams (similar to a skylight saddle). Alternatively, Base Supports can be flashed with standard Dektite rubber boots. For our square Base Supports, use a #6 Dektite boot (please see www.roofscreen.com/technical-info/product-literature.php for more information on this method).

Note: These flashing types and applications are only recommendations. Base Supports must be flashed per roofing system manufacturer's warranty requirements. It is the responsibility of the purchaser to verify that RoofScreen Flashing Boots are acceptable and pre-approved for warranty by the roofing system manufacturer.

More About Flashing Heights

8" Rule

It is common in the roofing industry to follow the standard that penetration flashings should extend a minimum of 8 inches above the roof surface. This standard was set many years ago and is generally accepted as the best roofing practice. However, the 8" standard was adopted by the industry for penetrations with open tops that would not prevent driven water, snow or ice from entering if it were to reach that height. The RoofScreen Roof Attachment system is different. The EPDM rubber gasket applied at the top of the flashing is compressed by the Base Cap during installation, creating a seal and preventing water, ice and snow from infiltrating.

RoofScreen Mfg. performed successful independent lab testing on the Roof Attachment System with only a 3" flashing height and had no leaks. Copies of the test report are available upon request. RoofScreen has also successfully negotiated the relaxation of the 8" standard with multiple brand name roofing materials manufacturers.

The decision on the height of the flashing above the roof membrane ultimately falls on the roofing contractor and the roofing material manufacturer. RoofScreen highly recommends consulting both and obtaining approval in writing for anything less than 8 inches, especially if a roof warranty is involved.

Extending Flashing Height When Required

In the event the Base Support needs to be raised to allow for the required flashing height, there are several ways to accomplish it.

- **Taller Base Support:** Standard Base Support heights are 8", 10", 12", 14" 16" and 18". These heights will accommodate most conditions; however, we also offer custom built heights if necessary. In the event that the Base Supports must be raised after they are installed, we offer 3" and 4" extensions that can be added in the field as illustrated in Figure 5.
- **Wood Block Spacer:** Solid wood blocking can be used to lift the Base Support to the desired height. The Base Support would then attach to the blocking the same way it would attach to a wood structure. The wood blocking must be appropriately attached to the structure.
- **Steel Spacer Hat:** Similar to using a wood block as outlined above, a steel spacer may be used. An effective method is to use a steel plate bent into the shape of a hat section as shown in Figure 6. The spacer hat must be appropriately sized and attached to the structure.

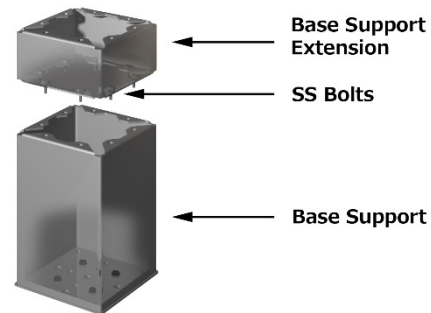

Figure 5

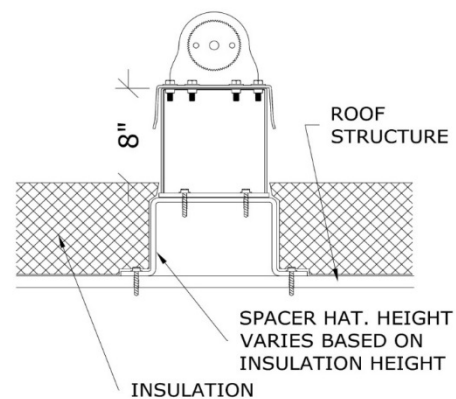

Figure 6